

Rotajet D60 PD

Material of construction:- 304
 Wash Pump:- 11kW
 Sump Capacity:- 560 Litre
 Wash Heating:- 36 kW
 Door:- Pneumatic Ram Assisted
 Interlocks: Door interlocked
 Temperature Control: Digital
 Wash Cycle timer: Digital
 Filtration: Coarse basket filtration
 Spray Bars: Upper and Lower
 Extraction: 250mm

Optional Extras:-
 Rinse stage
 Pressure Filtration
 Additional baskets
 Electric powered driven spray

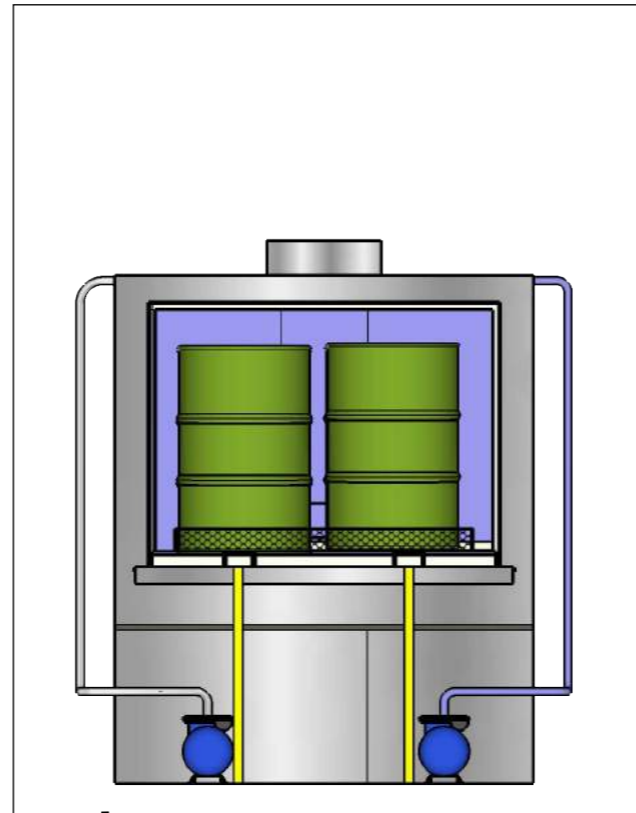

Rotajet D60 HD

Material of construction:- 304
 Wash Pump:- 11kW
 Sump Capacity:- 560 Litre
 Wash Heating:- 36 kW
 Door:- Hinged door
 Interlocks: Door interlocked
 Temperature Control: Digital
 Wash Cycle timer: Digital
 Filtration: Coarse basket filtration
 Spray Bars: Upper and Lower
 Extraction: 250mm

Optional Extras:-
 Rinse stage
 Pressure Filtration
 Additional baskets
 Electric powered driven spray

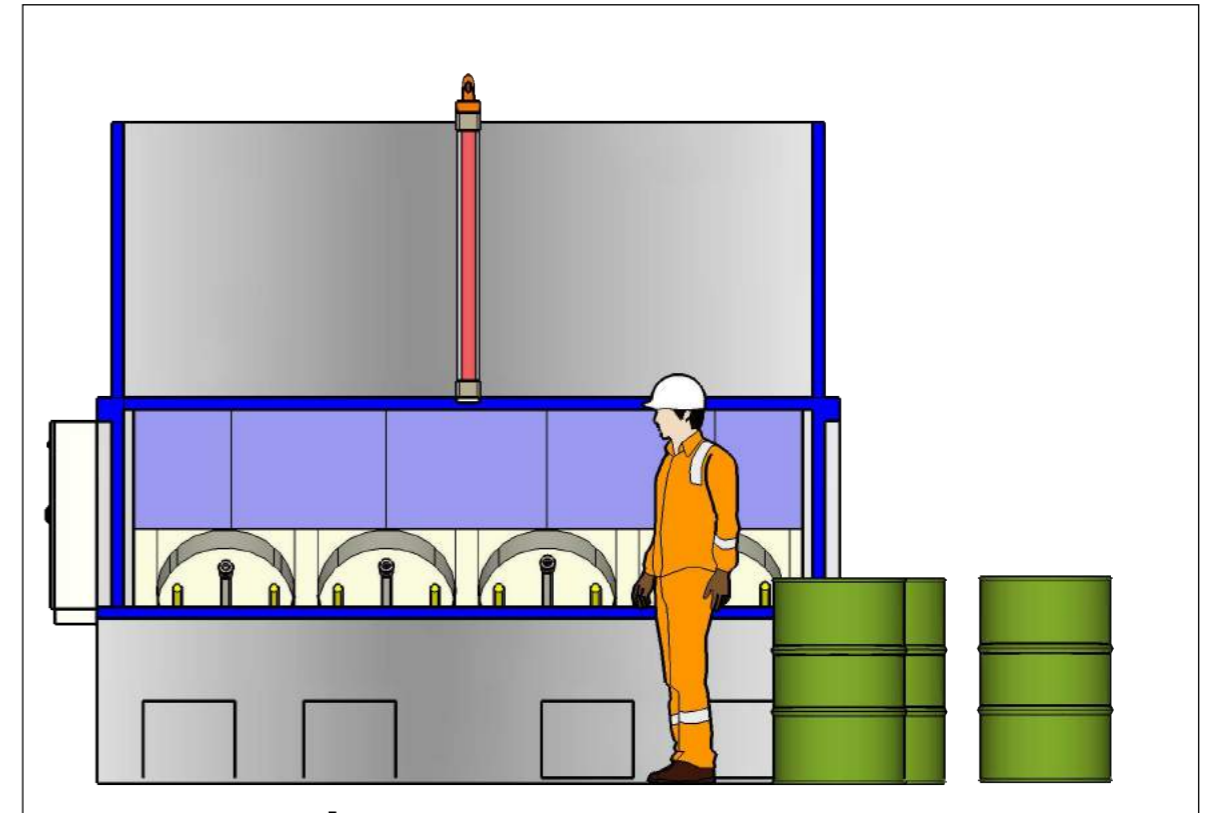

Rotajet DWx4 Drum Washer

Material of construction:- 304
 Wash Pump:- 11kW
 Sump Capacity:- 500 Litre
 Wash Heating:- 36 kW
 Door:- pneumatic door
 Interlocks: Door interlocked
 Temperature Control: Digital
 Wash Cycle timer: Digital
 Filtration: Coarse basket filtration
 Spray Bars: Upper and Lower
 Extraction: 250mm

Optional Extras:-
 Pressure Filtration
 Additional baskets
 Electric powered driven spray



ROTAJET SYSTEMS LIMITED
 UNIT 14, FLANSHAW WAY,
 WAKEFIELD, WF2 9LP.
 ENGLAND.
 TEL: 0044 1924 271446
 email: info@rotajet.co.uk
 www: www.rotajet.co.uk

CUSTOMER:- Veolia Ireland, Corrin Fermoy Co.Cork Ireland
 CONTACT:- Stephen Linehan
 PROJECT:- Cleaning Open Top 45 gallon drums x4 per cycle (MACHINE OPTIONS)

REVISIONS		
	MM/DD/YY	REMARKS
1	23 /01 /2018	...
2
3
4
5

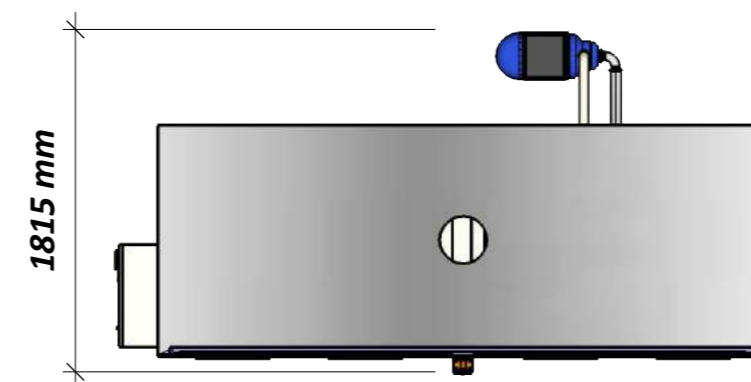
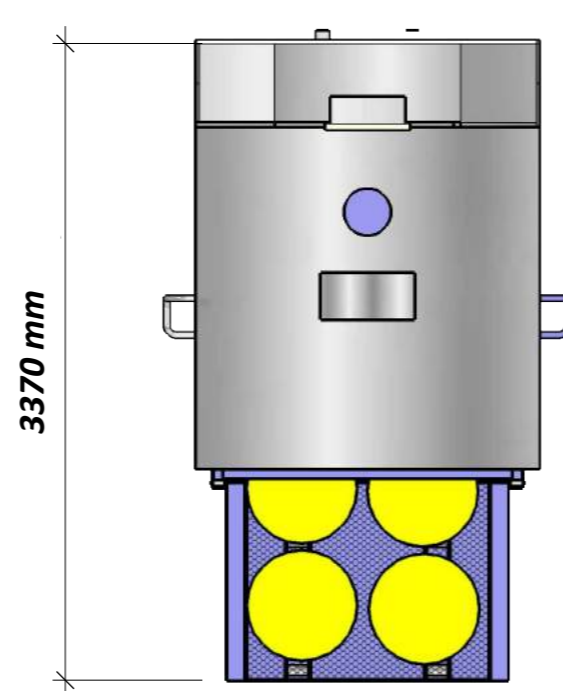
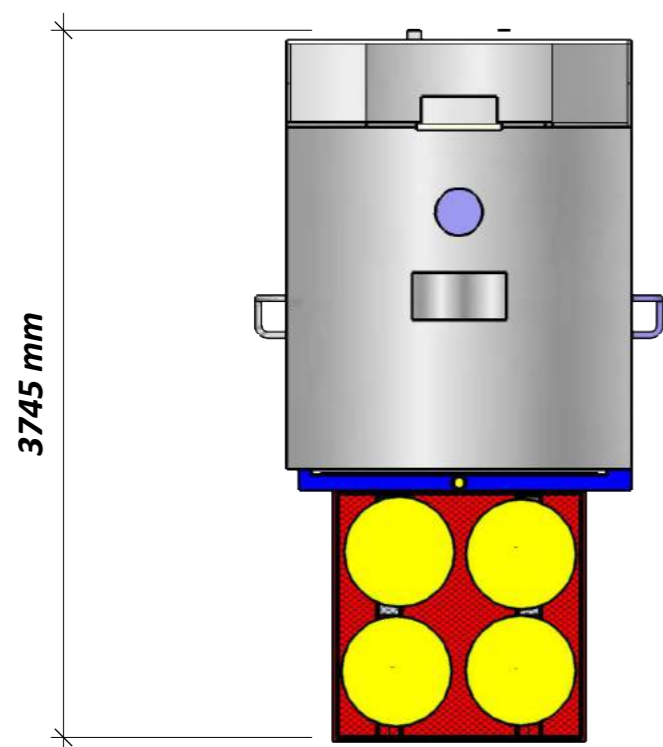
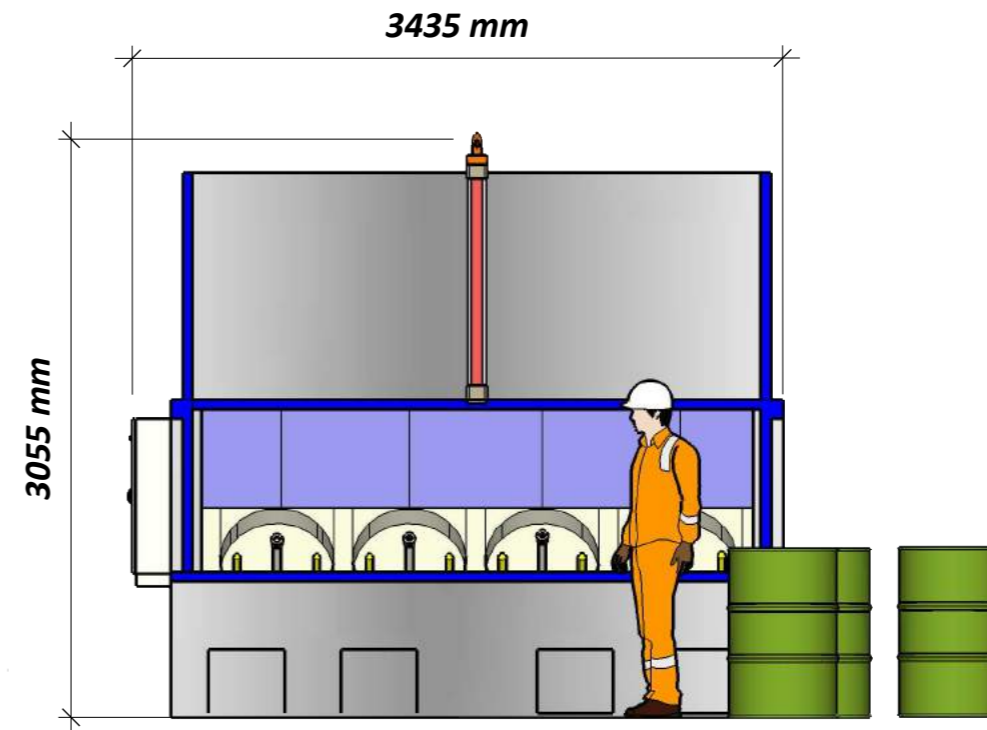
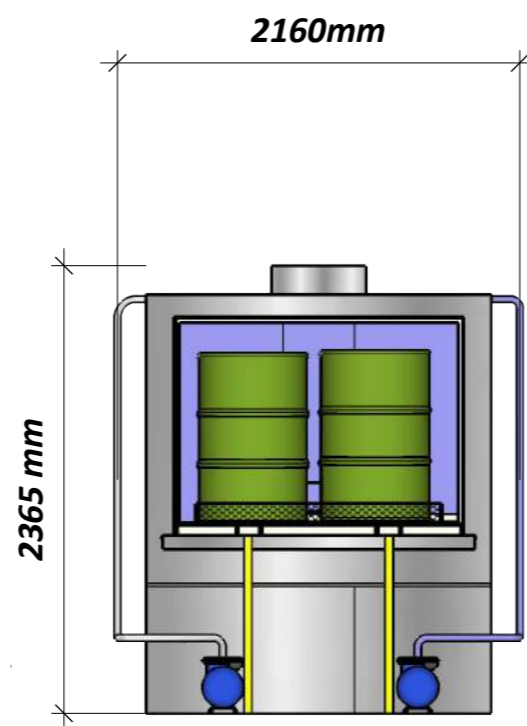
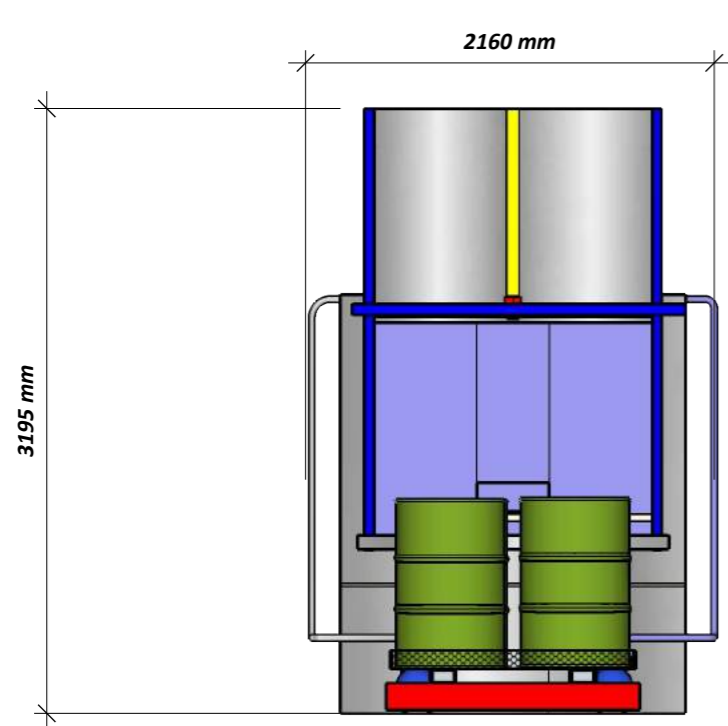

ROTAJET SYSTEMS LIMITED
 UNIT 14, FLANSHAW WAY,
 WAKEFIELD, WF2 9LP.
 ENGLAND.
 TEL: 0044 1924 271446
 email: info@rotajet.co.uk
 www: www.rotajet.co.uk

CUSTOMER:- Veolia Ireland, Corrin Fermoy Co.Cork Ireland

CONTACT:- Stephen Linehan

PROJECT:- Cleaning Open Top 45 gallon drums x4 per cycle (MACHINE OPTIONS)

REVISIONS		
	MM/DD/YY	REMARKS
1	23 /01 /2018	...
2	.../.../...	...
3	.../.../...	...
4	.../.../...	...
5	.../.../...	...

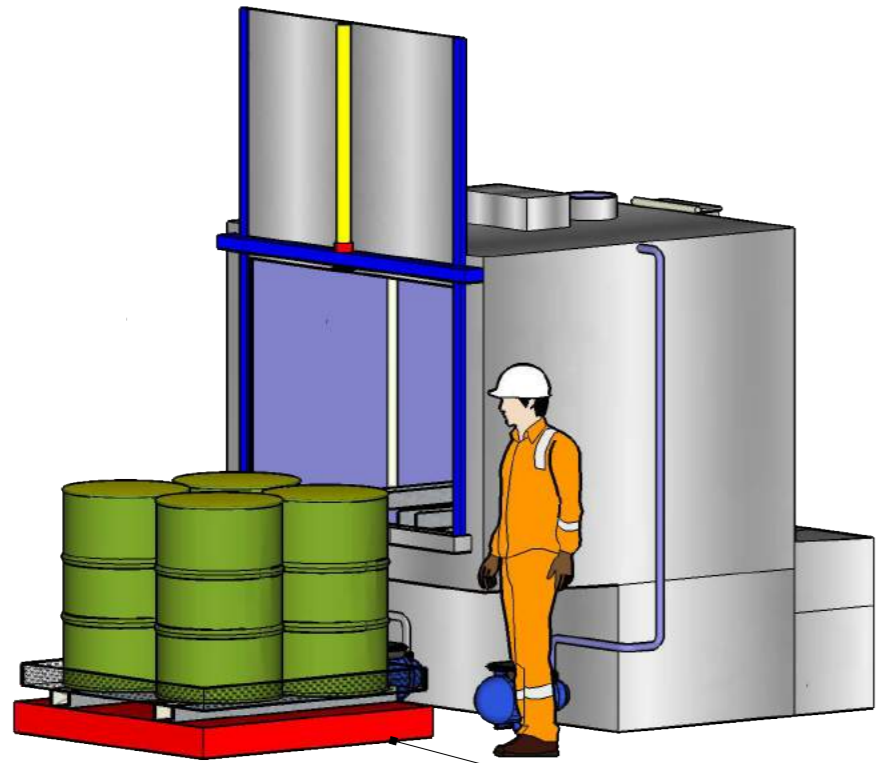

Scissor Lift for drums

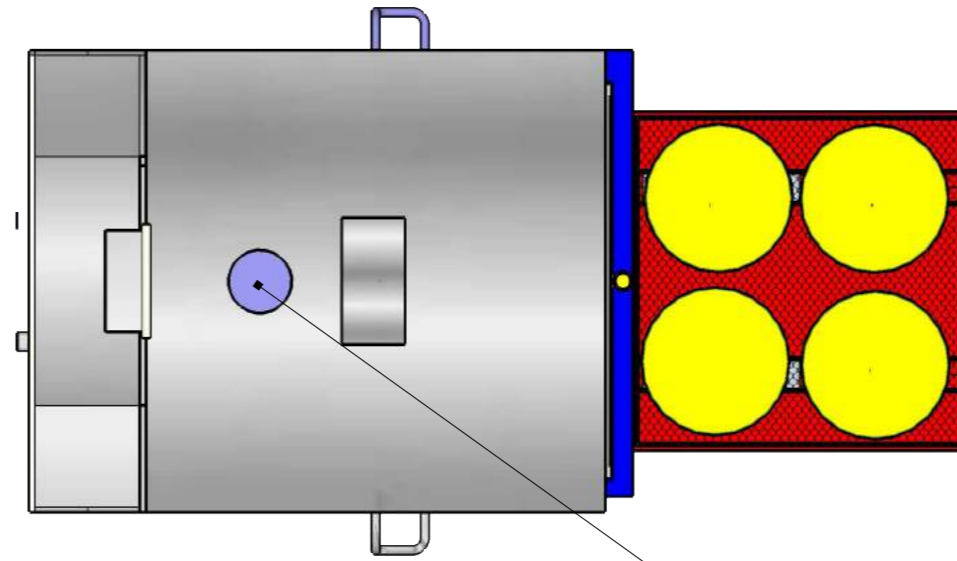

Extraction Point for Steam

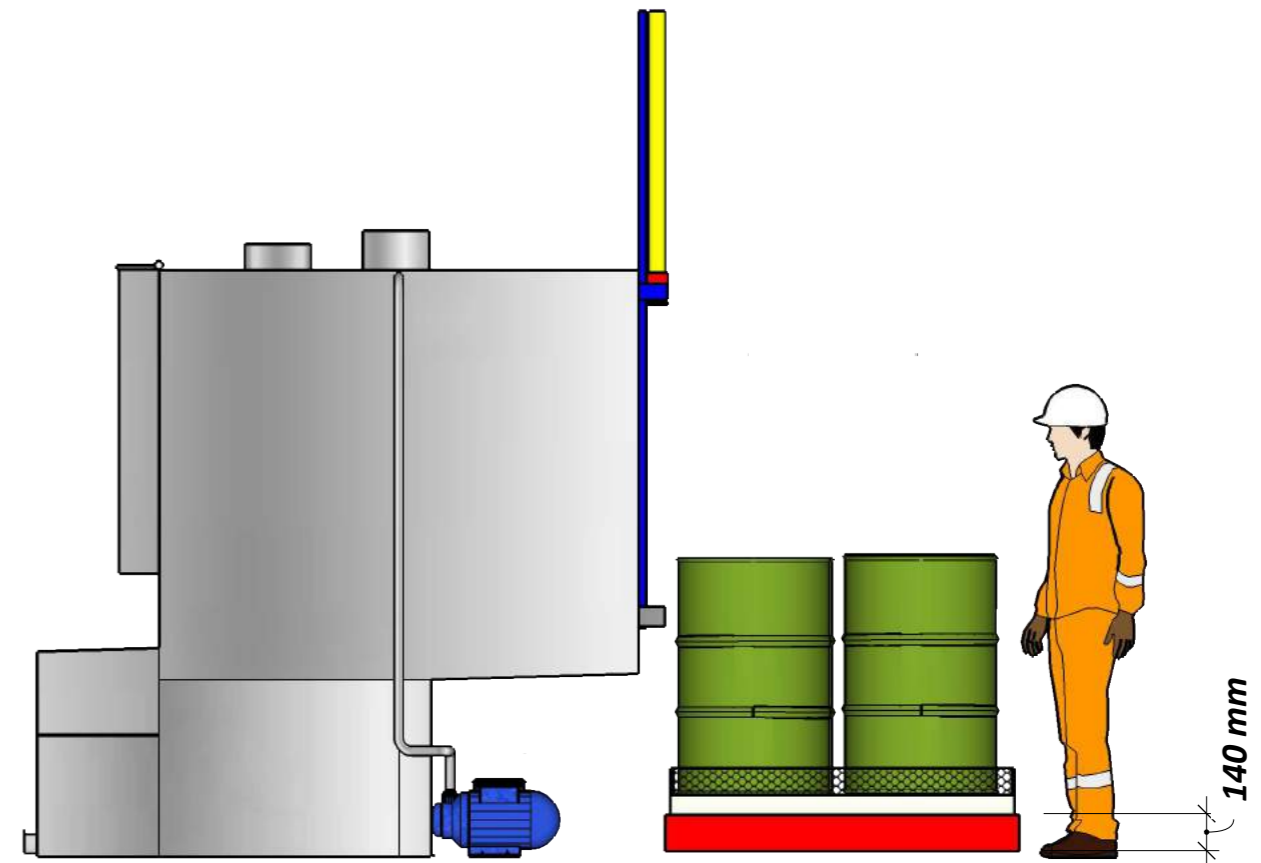
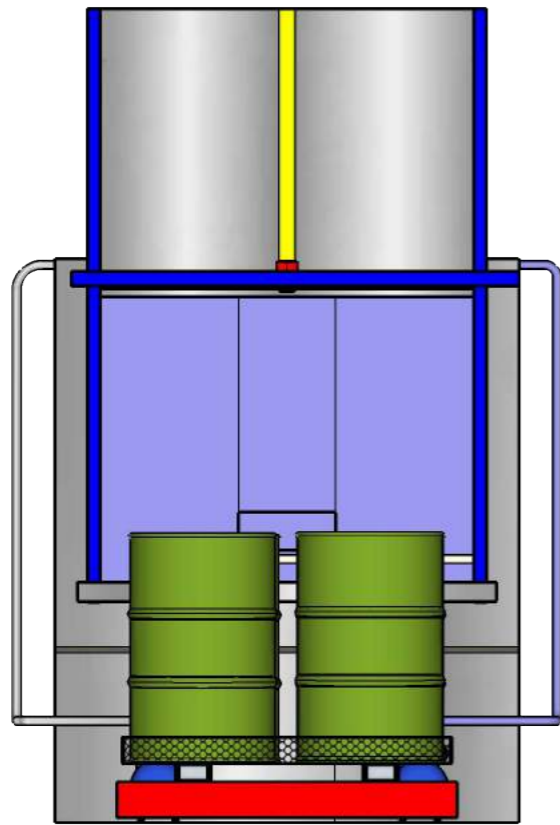

140 mm



ROTAJET SYSTEMS LIMITED
 UNIT 14, FLANSHAW WAY,
 WAKEFIELD, WF2 9LP.
 ENGLAND.
 TEL: 0044 1924 271446
 email: info@rotajet.co.uk
 www: www.rotajet.co.uk

CUSTOMER:- Veolia Ireland, Corrin Fermoy Co.Cork Ireland
 CONTACT:- Stephen Linehan
 PROJECT:- Cleaning Open Top 45 gallon drums x4 per cycle (MACHINE OPTIONS)

REVISIONS	
MM/DD/YY	REMARKS
1 23 /01 /2018	...
2	...
3	...
4	...
5	...

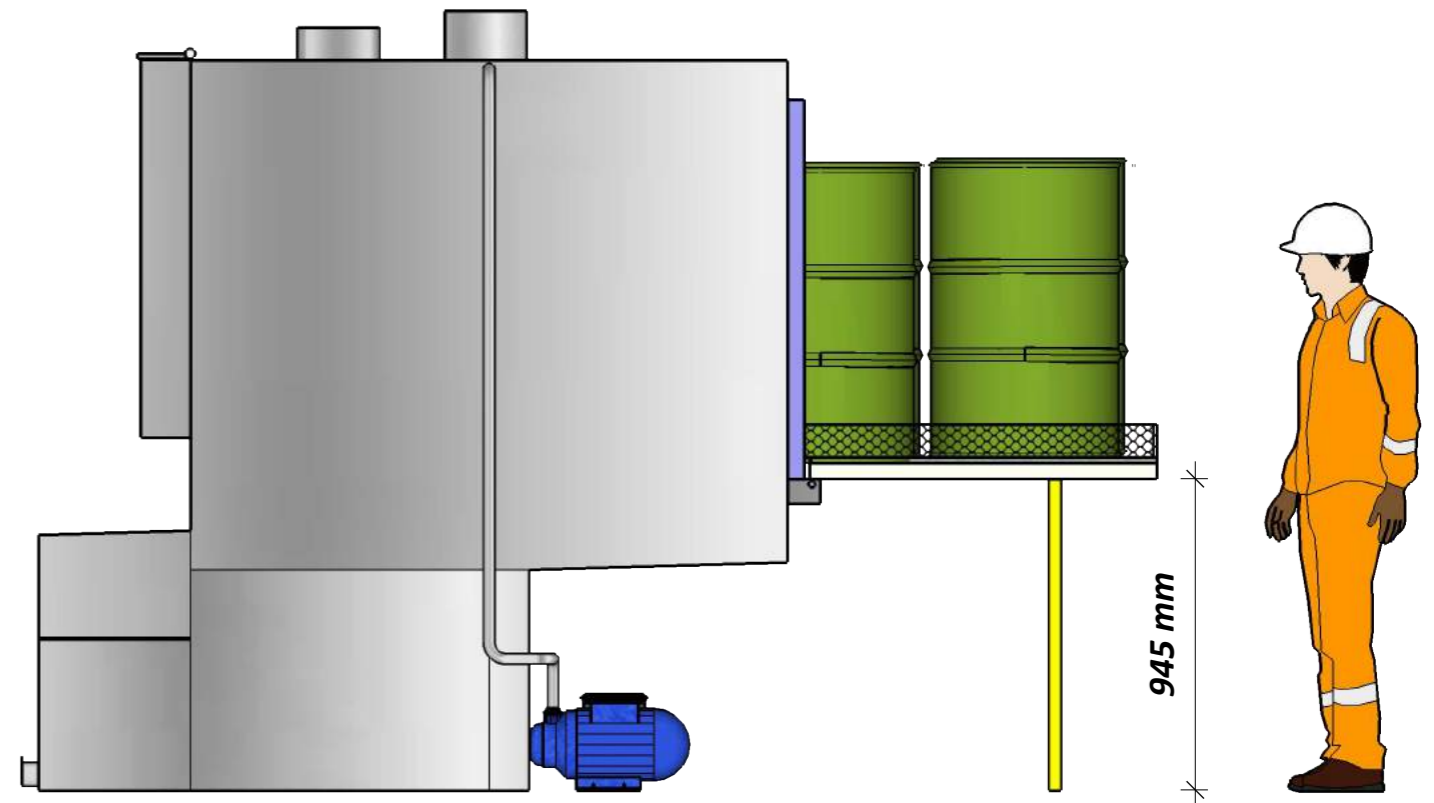
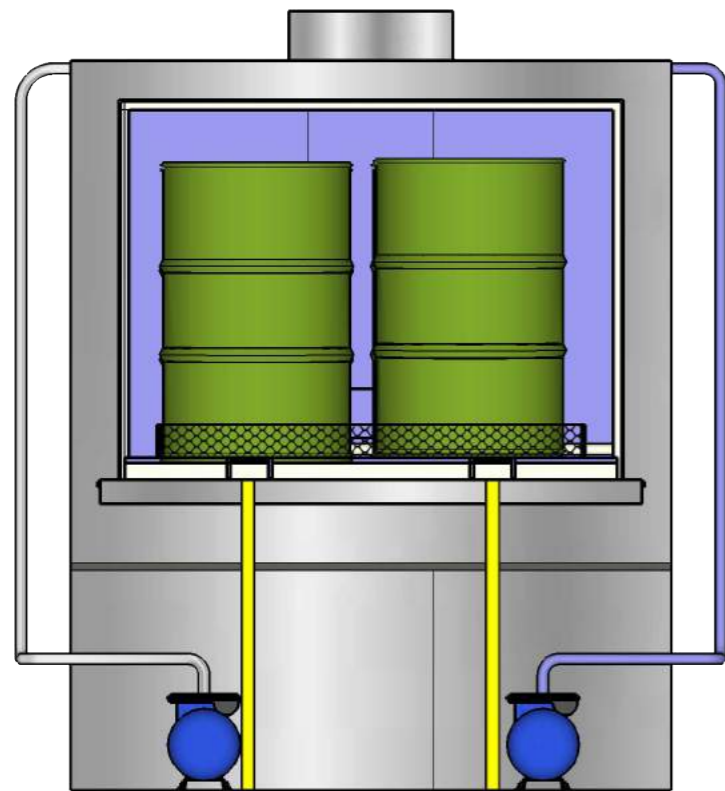
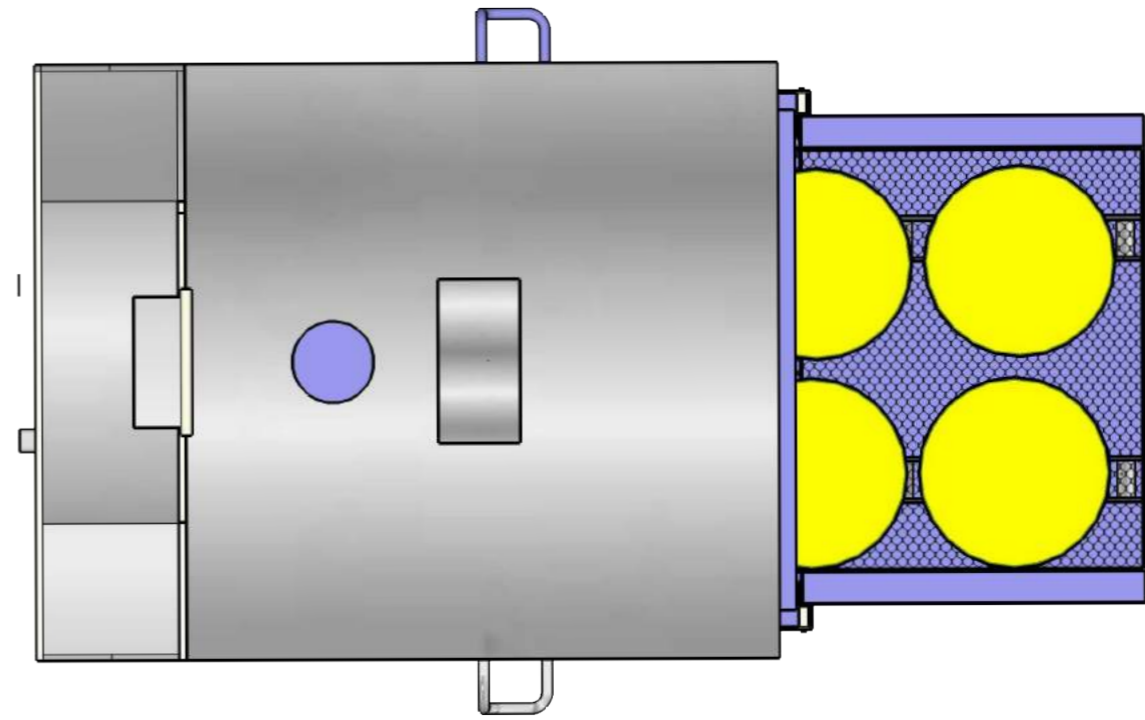
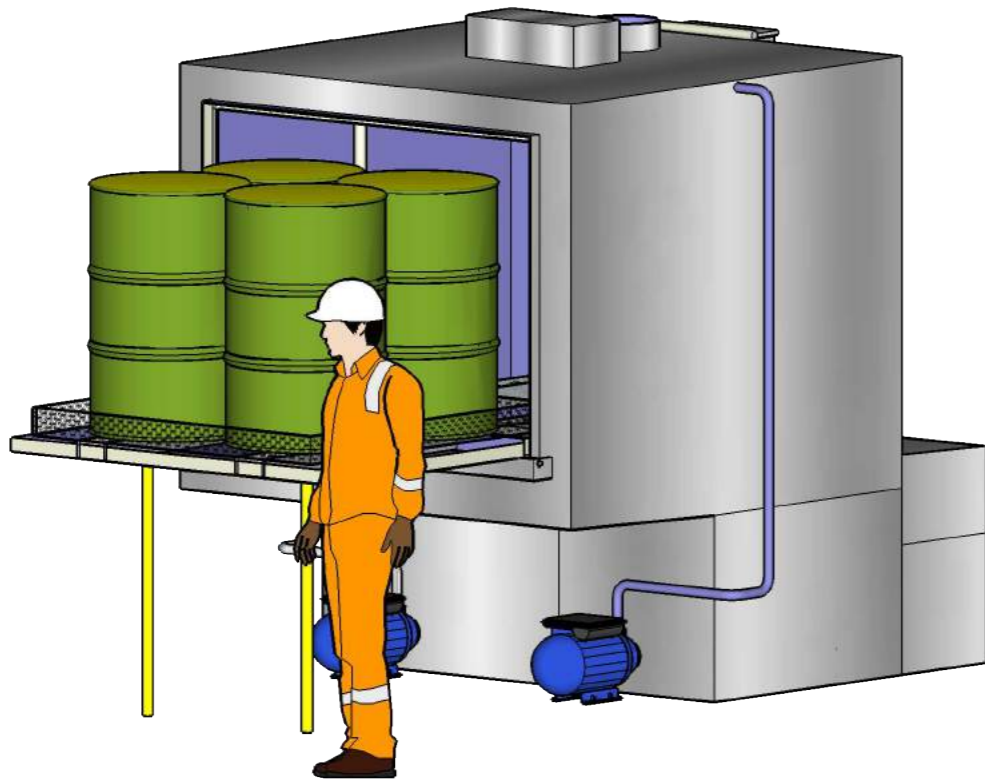

ROTAJET SYSTEMS LIMITED
 UNIT 14, FLANSHAW WAY,
 WAKEFIELD, WF2 9LP.
 ENGLAND.
 TEL: 0044 1924 271446
 email: info@rotajet.co.uk
 www: www.rotajet.co.uk

CUSTOMER:- Veolia Ireland, Corrin Fermoy Co.Cork Ireland
CONTACT:- Stephen Linehan
PROJECT:- Cleaning Open Top 45 gallon drums x4 per cycle (MACHINE OPTIONS)

REVISIONS		
	MM/DD/YY	REMARKS
1	23 /01 /2018	...
2	.../.../...	...
3	.../.../...	...
4	.../.../...	...
5	.../.../...	...

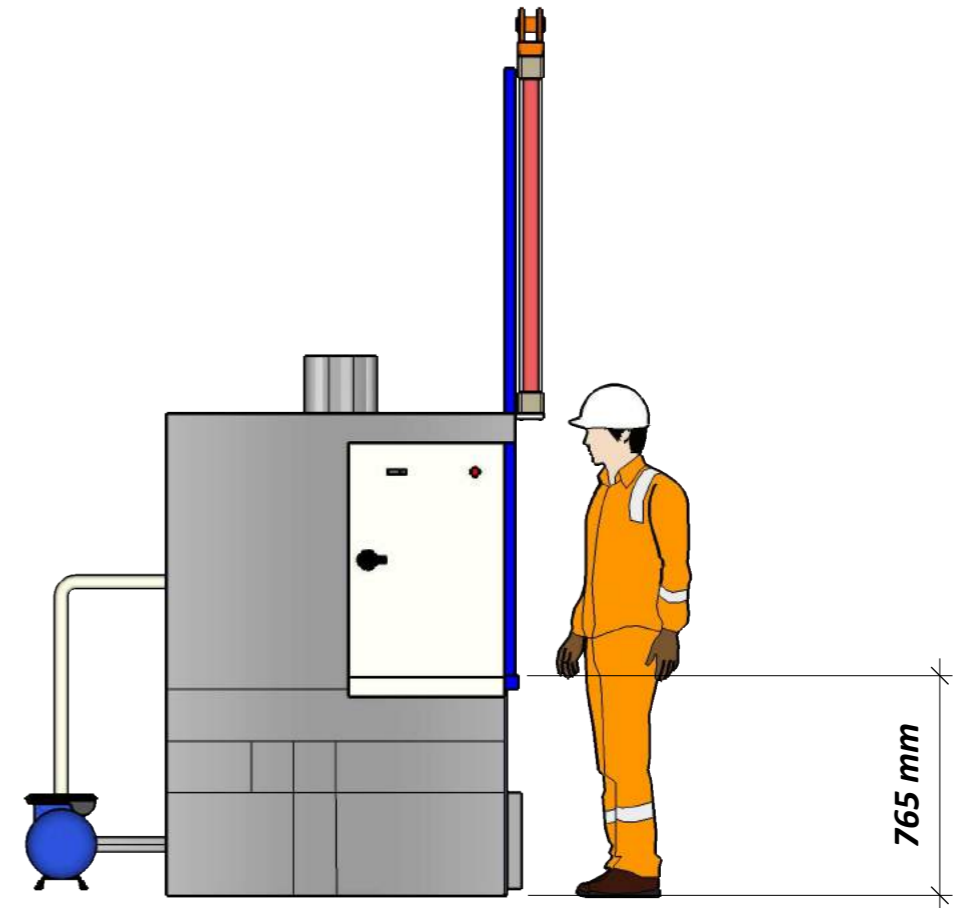
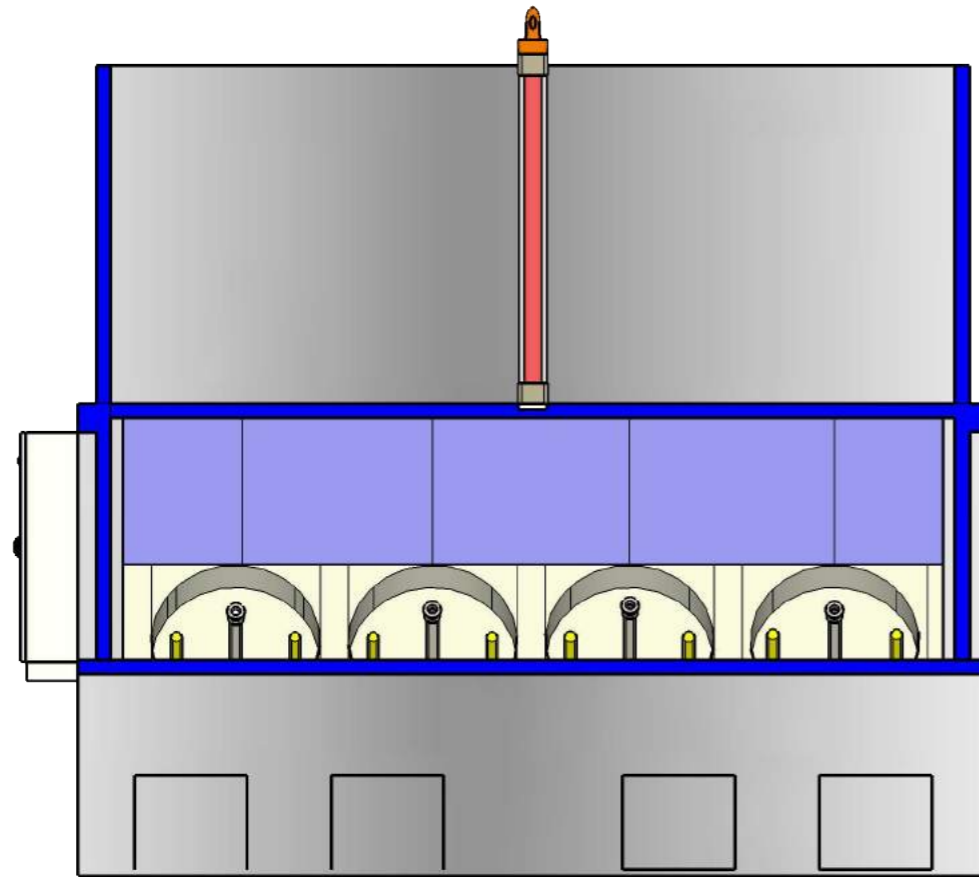
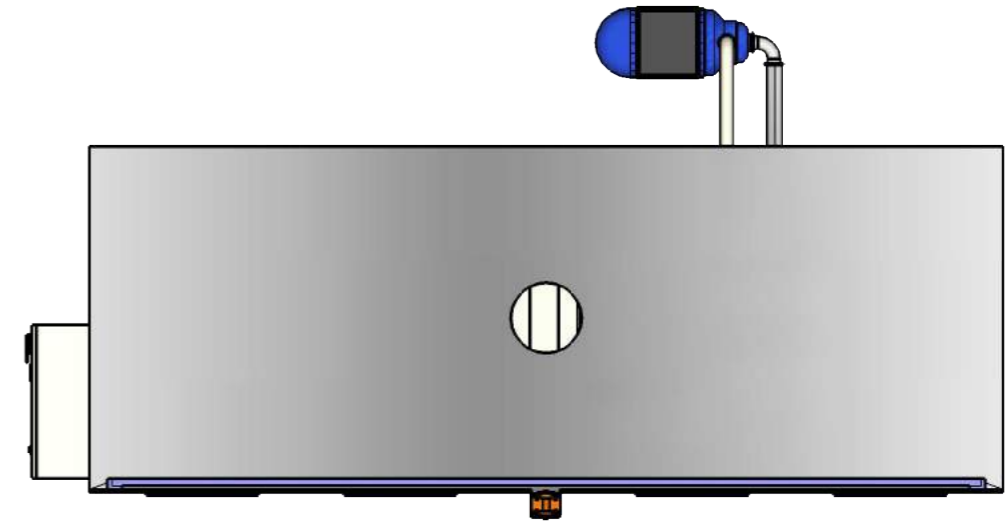
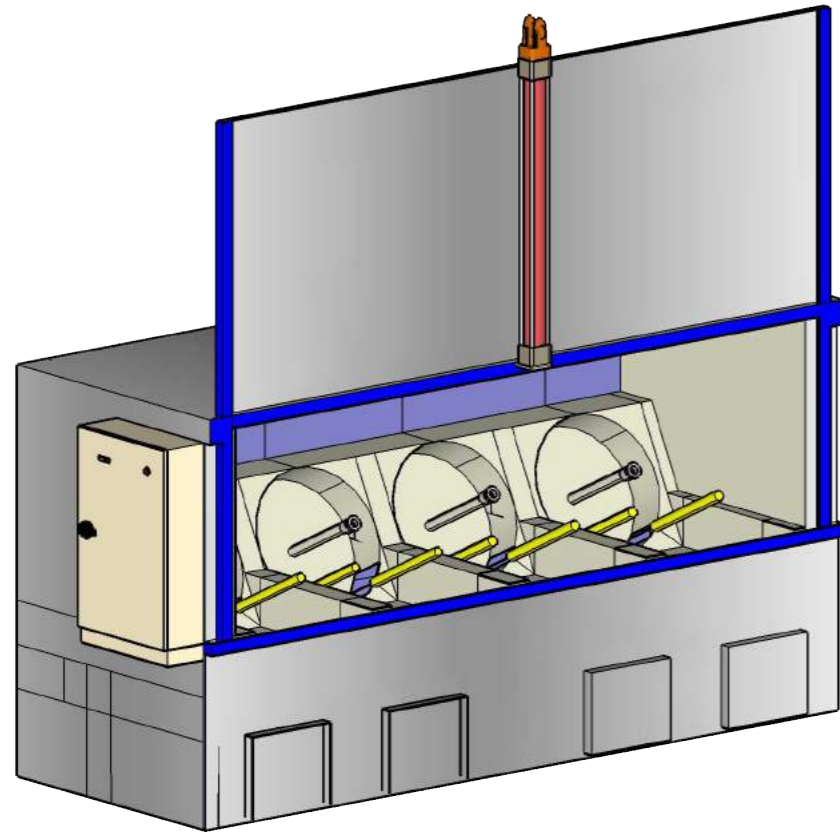

ROTAJET SYSTEMS LIMITED
 UNIT 14, FLANSHAW WAY,
 WAKEFIELD, WF2 9LP.
 ENGLAND.
 TEL: 0044 1924 271446
 email: info@rotajet.co.uk
 www: www.rotajet.co.uk

CUSTOMER:- Veolia Ireland, Corrin Fermoy Co.Cork Ireland
CONTACT:- Stephen Linehan
PROJECT:- Cleaning Open Top 45 gallon drums x4 per cycle (MACHINE OPTIONS)

REVISIONS		
MM/DD/YY	...	REMARKS
1	23 /01 /2018	...
2
3
4
5